

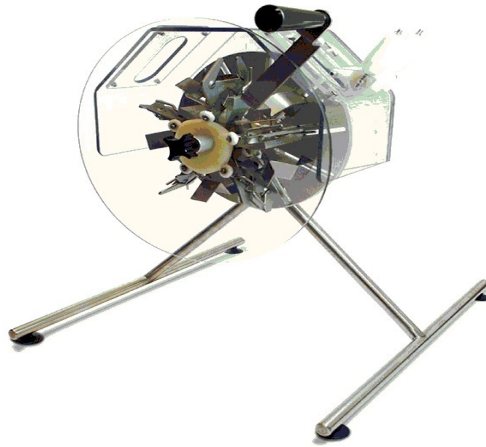

Sausage Making Equipment
Made in the USA

5-Head Hand Cranked Z-Linker



Owner's Manual

May 20201 - A

THIS PAGE INTENTIONALLY
LEFT BLANK

5-Head Hand Cranked Z-Linker

Owner's Manual

Table of Contents

Introduction	Page 1
Product Components	Page 2
Installation	Page 3
Operation	Pages 4 -5
Maintenance	Pages 6 – 7
Z-Linker Care Procedures	Pages 8 - 9
Troubleshooting	Pages 10 – 11
Parts List	Pages 12 – 14
Diagram 1: Hand Cranked Z-Linker Assembly	Pages 15 – 16
Diagram 2	Page 17
Diagram 3: Link Head Sub-Assembly	Pages 18 - 19

INTRODUCTION

1

The 5-Head Hand Cranked Z-Linker is a unique machine specifically designed for use by small volume sausage manufacturers. This linker, weighing approximately 17 pounds, is made of Stainless-Steel parts. It uses five (5) blades to form and cut individual links from a length of casing, cutting 80 links per minute from a standard 50-foot rope of sausage. Links can be made in a variety of sizes.

Portable, light weight, and low cost are the key features of the machine, which can be used either commercially or at home. Other features include:

- Simple maintenance
- Safe one-person operation
- Small size (20" x 20" x 22")
- Stainless steel linking blades
- Easy mounting and positioning
- Easily removable and adjustable components
- Can link casings 13 - 34mm in diameter with no adjustments

1. Linking Head Assembly

The linking head assembly is a device mounted on a disc that forms and cuts an individual sausage link from a stuffed length of sausage casing. Spring loaded blades are activated by rollers riding on two cams. Rotation of the disc via the handle around the stationary cams activates the rollers, which close the blades to form and cut the links. The four linking heads are mounted on the slotted disc in a predetermined location and are spaced equally around the disc. The cutters are hardened steel self-sharpening inserts.

2. Cams

Cams determine the finished link length and are available in several sizes. The cams are non-rotating, solid nylon specially contoured discs. Each cam is designed to accommodate one roller on each side of the linking head. The cams are held in place parallel on the shaft with a key and spacer.

3. Safety Cover/Guide Roll Bracket

The Lexan safety cover has a dual purpose. First, it is designed to protect the operator(s) from the rotating blades of the linking assemblies. In addition, it provides a feed path for the stuffed sausage strand.

Never operate the Z-Linker without the guard in place!

INSTALLATION

3

The 5-Head Hand Cranked Z-Linker may be placed into immediate service after post-receipt inspection reveals no flaws.

The Z-Linker must be placed on a smooth, solid surface for a safe and maximum performance. The surface or table should also be at a comfortable height for the operator to not only feed in the strand of sausage but to also turn the linker handle. Installation considerations include the following:

- Provide a flat firm surface for the Z-linker. Surface can be either a food-grade ready stainless steel or white nylon table.
- Access to a stuffer (sold separately)
- Make sure sausage coil is laid out for easy feeding into linker
- Use a flat stainless-steel tray or tote to collect links once made
- Commercial users should adhere to USDA cleanliness standards

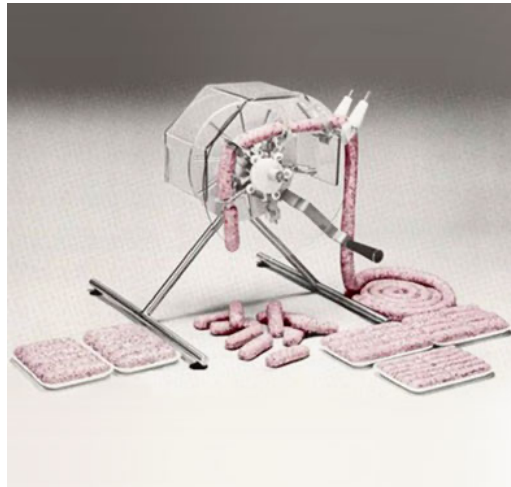

Operating the 5-Head Hand Cranked Z-Linker is a simple process that requires only one operator, with minimal training. A sausage stuffer (purchased separately) is required for providing the stuffed length of sausage casing for the linker. To begin manufacturing sausage links proceed as follows:

- Ensure the Hand Cranked Z-Linker is firmly affixed either close by or adjacent to the sausage stuffer
- Place a tray or conveyor at the discharge end of the linker to receive the cut links
- Fill the sausage casing and arrange in neat coil as close as possible beneath the feed roller
- Immediately feed one end of the stuffed sausage casing into the machine feed slot or sausage guide assembly. **At the same time** grasp

- the handle of the linker and turn it so that the linking head assembly picks up the end of the stuffed strand and carries it over the top of the linker.
- Turn the handle in a slow, even motion to engage the linking heads in a smooth “pinch and cut” action, forming the link
- Continue until all casing has been consumed / sausage links made
- Clean linker immediately after use (*See cleaning procedures on P8*)
- Package / refrigerate links

Maintenance: Linking Head Assembly

6

Correct adjustment of the linking head assemblies is critical to proper linking function. Linking Head Adjustment is done at the high point of the cam (maximum head closure). It is best done by loosening the cam shaft lock bolt and rotating the cam until the high point of the cam faces up (12 o'clock). Then retighten the cam shaft lock bolt. **NOTE:** The keyway indicates the high point of the cam.

The linking head can now be adjusted by moving the head up or down in the slotted disc with the nylon rollers of the individual blades positioned on the high point of the cam.

Proper adjustment of the link heads will produce $\frac{1}{4}$ " – $\frac{3}{8}$ " overlap of the cutting inserts. It is ABSOLUTELY CRITICAL that free play be allowed in this adjustment. Push down on the top of the blade. If you cannot lift the roller off of the cam at the high point it is over adjusted or bottomed out. **NOTE:** *OVER-ADJUSTMENT will cause severe damage to the linking heads.*

After properly adjusting the linking heads, the cams must also be adjusted for proper timing of the cutting action.

MAINTENANCE: CAMS

7

Cams are available in several sizes. When replacing cams make sure the lettering on the cams faces out towards the user. Otherwise, the unit will not work. To change a cam, do the following:

- Remove linking heads
- Pull cams off the keyed shaft
- Install in reverse order

Cam timing after adjustment should be at the high point. Position high point between 6 – 8 o'clock, or as works best for dropping finished product into tray / tote.

Z-LINKER CARE PROCEDURES

8

DAILY CARE	PROCESS
All machine parts that contain residual meat or sausage products, or any part that may be dirty <i>NOTE: Do NOT use caustic or acid-based cleaners on any part of the machine that will touch meat products</i>	<ol style="list-style-type: none">1. Clean with USDA approved cleaner or mild detergent2. Blow dry parts3. Spray with USDA food grade oil
Moving Parts	<ol style="list-style-type: none">1. Inspect for any loose fasteners or parts2. Tighten any loose parts

MONTHLY CARE	PROCESS
Entire System	<ol style="list-style-type: none">1. Inspect2. Tighten all fasteners3. Replace all parts that appear worn or cracked

QUARTERLY CARE	PROCESS
Compression Springs	Replace springs that appear weakened or collapsed
Teflon Washers	Replace Teflon Washers, if worn
Linking Head Cutting Surfaces	<ol style="list-style-type: none"><li data-bbox="862 663 1386 762">1. Check overlap and adjust if necessary<li data-bbox="862 842 1386 940">2. Check Insert wear and interference<li data-bbox="862 1020 1386 1119">3. Replace heads having little or no interference

PROBLEM	CORRECTION PROCESS
Links are crimped but not properly cut apart	<ol style="list-style-type: none"><li data-bbox="818 411 1386 569">1. Check arm casting and blades to ensure they are not bent or warped. Replace if damaged.<li data-bbox="818 646 1370 741">2. If arm and blade assemblies are not warped, then adjust overlap
Links are cutting but ends are ragged, torn, not bent, or warped	<ol style="list-style-type: none"><li data-bbox="818 827 1386 984">1. Check arm casting and blades to ensure they are not bent or warped.<li data-bbox="818 1062 1362 1157">2. Replace arm casting, blades, or both if necessary<li data-bbox="818 1234 1378 1392">3. Check compression springs for damage (part 00x69). Replace if necessary.<li data-bbox="818 1470 1338 1686">4. Check position of 'Z' bars on blade. Make sure the distance between the sausage coil and feed-in roller is minimized.

<p>Double link formed without a crimp in the center</p>	<ol style="list-style-type: none">1. Check for foreign material wedged in blades or inserts, removing any foreign material found.2. Check torsion springs to determine if broken, replacing if necessary.3. Inspect bearing and Teflon washers located on pivot shaft for excessive wear / flattened / torn. Replace if necessary.
<p>Lack of crimp and torn ends on large diameter sausage</p>	<ol style="list-style-type: none">1. Check faceplate timing2. Adjust so that linking heads have a maximum opening at the faceplate

5-Head Hand Cranked Z-Linker Parts List

WHEN ORDERING PARTS KEEP THE FOLLOWING IN MIND:

- Cam choice depends on the cut size desired
- The unit comes with one (1) CAM installed. You can order other cams to obtain links of varying size.

INDEX NUMBER	Part #	Quantity Provided	Description
1	01X73	1	Frame
2	01X74	1	Main Shaft
3	01X75	2	External Retaining Rings
4	01X76	1	Stainless Steel Screw 5/16 -18 x1"
5	15X04	1	Guide Roll Bracket Sub-Assembly
6	01X78	2	Flanged Bushings
7	01X79B	1	Disc 10"
8	01X80	1	Stainless Steel Key (Cam)
9A	01X81-5H	1	Cam – 4" cut
9B	01X82-5H	1	Cam – 5 1/4" cut
9C	01x83-5H	1	Cam – 5 1/2" cut
9D	01x84-5H	1	Cam - 6" cut
10	02X13	1	Cam Spacer
11	01X06-TL	1	End Cap Retainer

12	01X37-HC	4	Arm / Blade Sub Assembly
13	01X38-5H	5	Arm Sub-Assembly
17	00X64-5H	5	Teflon Washer - .015
25	00X33-5H	10	Stainless Steel Washer #10
26	01X40-5H	10	Roller Sub-Assembly
29	00X36-5H	10	Self-Locking Retainer Ring
30	01X13-5H	5	Cylindrical Bearing
31	00X69-5H	5	Compression Spring
32	00X97-5H	5	Stainless Steel Screw 8-23 x 1/2"
33	00X66-5H	5	Spring Holder
34	00X70-5H	5	Torsion Spring
35	01X86-5H	5	Clamp Plate
36	01X87-5H	10	Stainless Steel Screw 10-24 x 7/8"
37	01X88-5H	4	Adjustable Casing Support
39	01X90-TL	1	Taper Handle, Stainless Steel Bolt, Metal Support Sub-Assembly
40	01X01	2	Horizontal Roller
41	01X92	1	Tapered Handle
42	01X93	1	Shoulder Stainless Steel Screw 5/16 x 1"
43	01X94	1	Front Disc Guard
44	15X01	1	Cover Without Guide Roll Sub- Assembly

45	01X95-5H	10	Stainless Steel Screw 10/24 x 7/8"
46	00X46	2	Pin, Vertical Guide Disc Guard
47	01X07	1	Cover Guard Pin
48A	01X97	1	Front Plastic Knob
48B	01X98	1	Back Plastic Knob
50	02X01	1	Guide Roll Bracket
51	02X02	1	Acorn Stainless Steel Nut 1/14" - 20
52	00X99	1	Fixed Horizontal Roller
53	00X98	2	Vertical Guide Roller
54	02X03	4	Rubber Feet
61	00X65	4	Teflon Washer .030
62	02x11	1	Nut Driver 1/4"
63	02X12	1	Nut Driver 5/16"
64	01X02	1	Adjustable Pin
65	05X02-5H	5	Complete Blade Exchange minus arm

DIAGRAM 1: HAND CRANKED Z-LINKER ASSEMBLY

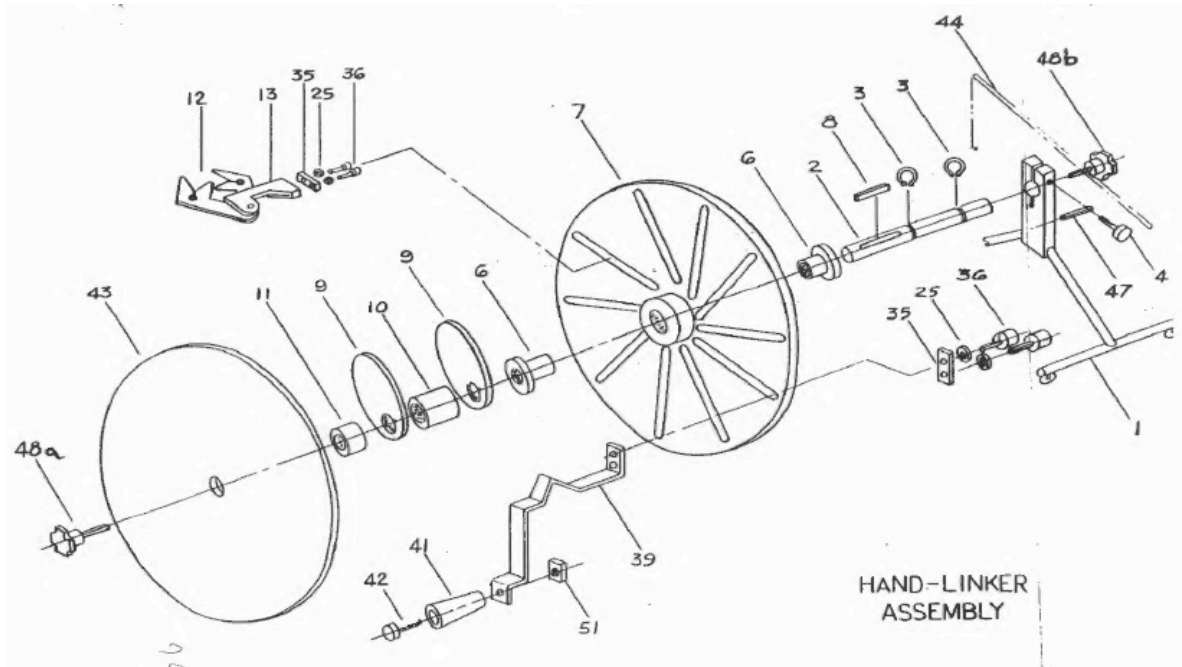

- There are a total of 30 parts that make up the Z-Linker Assembly
- Three (3) components are used twice: Items 9, 6, and 3
- See Diagram Key on Page 16

DIAGRAM 1 KEY					
48A	Front Plastic Knob	42	Should Stainless Steel Screw 5/16 x1"	1	Frame
43	Front Disc Guard	41	Tapered Handle	47	Cover Guard Pin
11	End Cap Retainer	51	Acorn Stainless Steel Nut 1/14"-20	4	Stainless Steel Screw 5/16-18X1
9	Cam (Varied Sizes)	39	Taper Handle, Stainless Steel Bolt, Metal Support Sub-Assembly	44	Cover Without Guide Roll Assembly
10	Cam Spacer	35	Camp Plate	48B	Back Plastic Knob
6	Flanged Bushing	25	Stainless Steel Washer #10		
7	10" Disc	36	Stainless Steel Screw 10-24 x 7/8"		
2	Main Shaft			12	Arm/Blade Sub-Assembly
8	Stainless Steel Key			13	Arm Sub-Assembly
3	External Retaining Ring			35	Clamp Plate
				25	Stainless Steel Washer #10
				36	Stainless Steel Screw 10-24 x 7/8"

DIAGRAM 2 - DISC 43

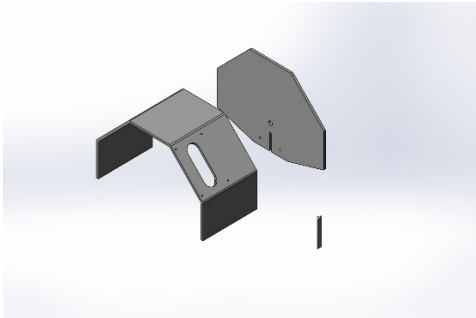

15X01 - Disc Cover Guard

15X04 – Guide Roller Assembly

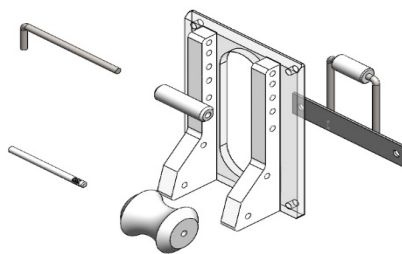
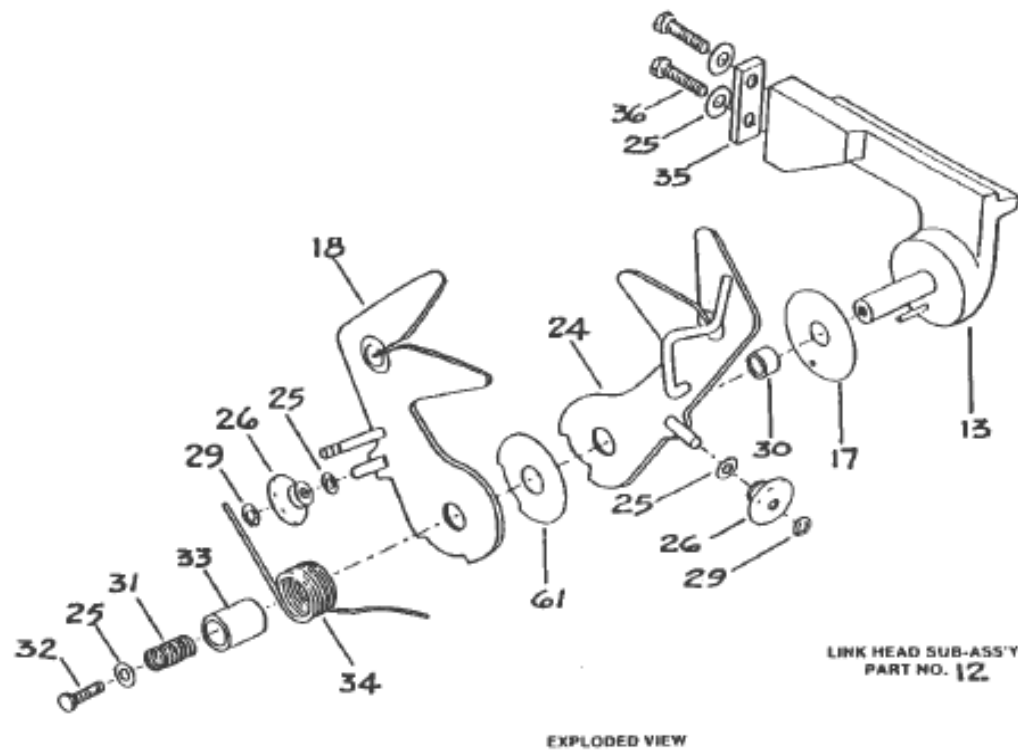

DIAGRAM 3: LINK HEAD SUB-ASSEMBLY



- There are total of 20 parts for the Link Head Sub-Assembly Part 12
- Two (2) components are used twice: Items 26 and 29
- One (1) component is used four times: Item 25
- See Diagram Key on Page 19

DIAGRAM 3 KEY: LINK SUB-ASSEMBLY			
32	Front Plastic Knob	61	Teflon Washer .030
25	Stainless Steel Washer #10	24	<i>See notes below</i>
31	Compression Spring	30	Cylindrical Bearing
33	Spring Holder	17	Teflon Washer (.015)
34	Torsion Spring	13	Arm Sub-Assembly
29	Self-Locking Retainer Ring	36	Stainless Steel Screw 10-24 X 7/8"
26	Roller Sub-Assembly	35	Clamp Plate
18	<i>See notes below</i>		

NOTES:

- Item 18 is the left half of the blade set
- Item 24 is the right half of the blade set
- These two items are not sold separately. Together with the springs and washers they comprise part # 05x02 on the master parts list.